

# Installation Instructions for



## EcoFount Series

*Congratulations, you have just purchased the finest watering fountain on the market. This unit is built to give you excellent service when properly installed and maintained. Please follow instructions carefully. Read and understand all instructions before installing*

Ritchie Industries, Inc.  
800-747-0222  
[www.ritchiefount.com](http://www.ritchiefount.com)

Part # 17967  
May 24, 2018

# EcoFount Series

## Installation Instructions

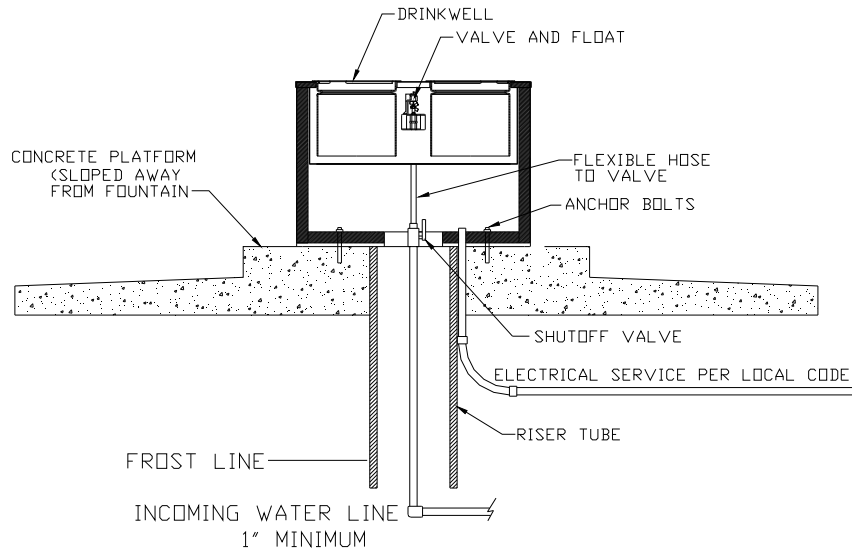

A. **Location** - Installing the fountain in a location that offers protection from the wind will enhance the performance of the fountain. Livestock will tend to gather in this protected area, enticing them to drink more. Access panel should be opposite of prevailing winter wind to give additional protection to the supply line.

B. **Water Supply Line** - Horizontal underground water line should be sized to account for pressure drop, relating to distance, and placed well below frost line. A one-inch vertical supply pipe is recommended. A shut-off valve should be installed under fountain to allow for easier servicing. For optimum serviceability, a stop and waste valve can be installed below frost level to drain water back when unit is not in use. Vertical supply line must be centered in riser tube to provide an air space between the line and frozen ground outside of tube. Flush water supply line thoroughly before connection to fountain. Water supplies with foreign material such as sand, rust, etc. may require a filter to keep fountain valve working properly.

C. **Riser Tube** - Install a riser tube and extend it at least one foot below frost line or down to horizontal underground water line. Top of riser tube should be flush with top of concrete. For optimum water line protection, use the 12" diameter insulated Ritchie Thermal Tube, part numbers and sizes are shown in the table. Tube opening must be kept clear.

Ritchie Thermal Tube	
Part #	Description
18158	1' Top Section
16417	2' Top Section
16612	4' Top Section
16416	2' Extension

**NOTE:** *The supply line touching the riser tube is the most common cause of the supply line freezing. Do not surround the supply line with insulation, wood, or other foreign material. Any foreign material in the tube may cause frost to migrate to the supply line causing it to freeze.*

D. **Mounting Platform** - A concrete platform must be provided for all fountains. Use a minimum of 4" thick, (6" recommended thickness), and 16' square for cattle fountains (otherwise large enough to accommodate fountain), and an additional 4" step on top of the platform extending 18" out from each side of the unit. This will protect the unit from manure handling equipment, as well as discouraging animals from defecating in the fountain. The concrete step and platform should slope away from the fountain for drainage. A rough broom finish on concrete surface provides better footing for livestock.

E. **Preparing the Bottom** - Apply the provided foam weather stripping to the bottom of the unit, around the outside edge of the fountain.

F. **Hold-Downs** – EcoFount Fountains have mounting locations molded into the base inside the unit. Use of Ritchie stainless steel anchor bolts (not included) is recommended for concrete installations. Anchor bolts are available from Ritchie in packages of two, part #16555. The trough may be removed to allow easier access to the bolt down location.

G. **Hose Connection** – Remove access panel. Do not remove access panel bolt, removing bolt will allow retainer to fall off back. Loosen bolt until latch can be moved to allow panel to be removed. With panel removed cut hose to proper length and connect to shut off valve. Adapter is provided to make connection to shut-off valve.

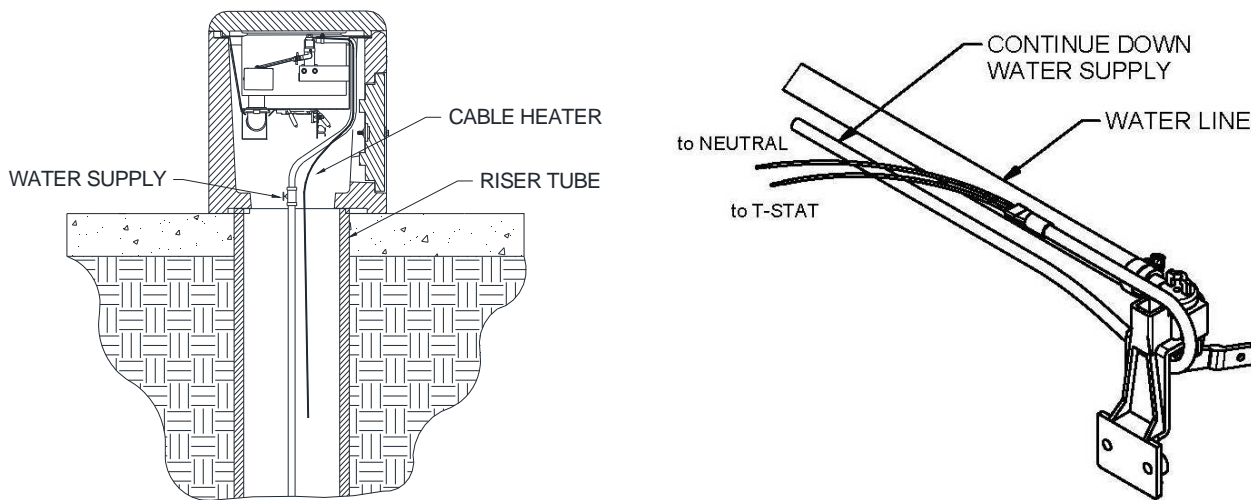

H. **Cable Heater** – Uncoil cable heater and loop around the valve. Attach the remaining part of the cable heater to the water supply, as far down the riser tube as possible with the cable twist ties provided. This heater is water tight, but should not be immersed in water. Heater may cross over itself, but should not be tightened at those locations.

**CAUTION:** Installation must not cause any strain on heater wiring connections. Avoid heater damage caused by hot spots due to its leads lying close to each other. Also, do not wrap additional insulation around heater.

I. **Electrical Connection** - A means for disconnection must be incorporated in the fixed wiring in accordance with the wiring rules. For wiring connections, see wiring diagram. Make connections according to the wiring diagram below.

**WARNING!** – Check the nameplate for your unit. Only connect 120VAC to a 120V Unit.

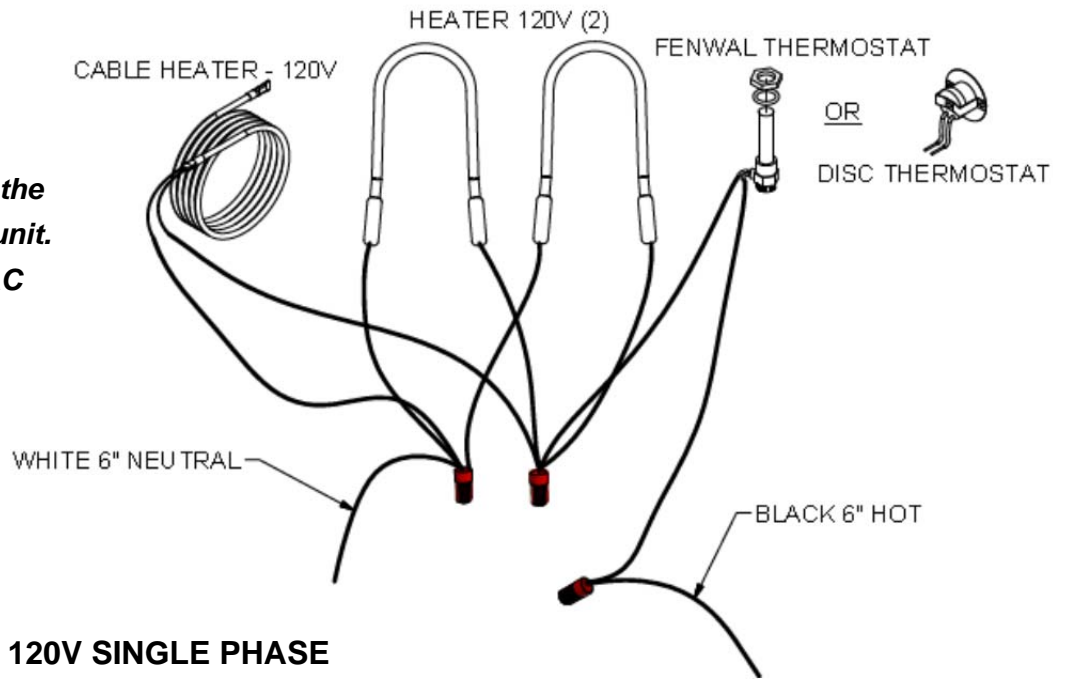

**WIRING DIAGRAM 120V SINGLE PHASE**

**WARNING!** – Check the nameplate for your unit. Only connect 230-240VAC to a 240V Unit.

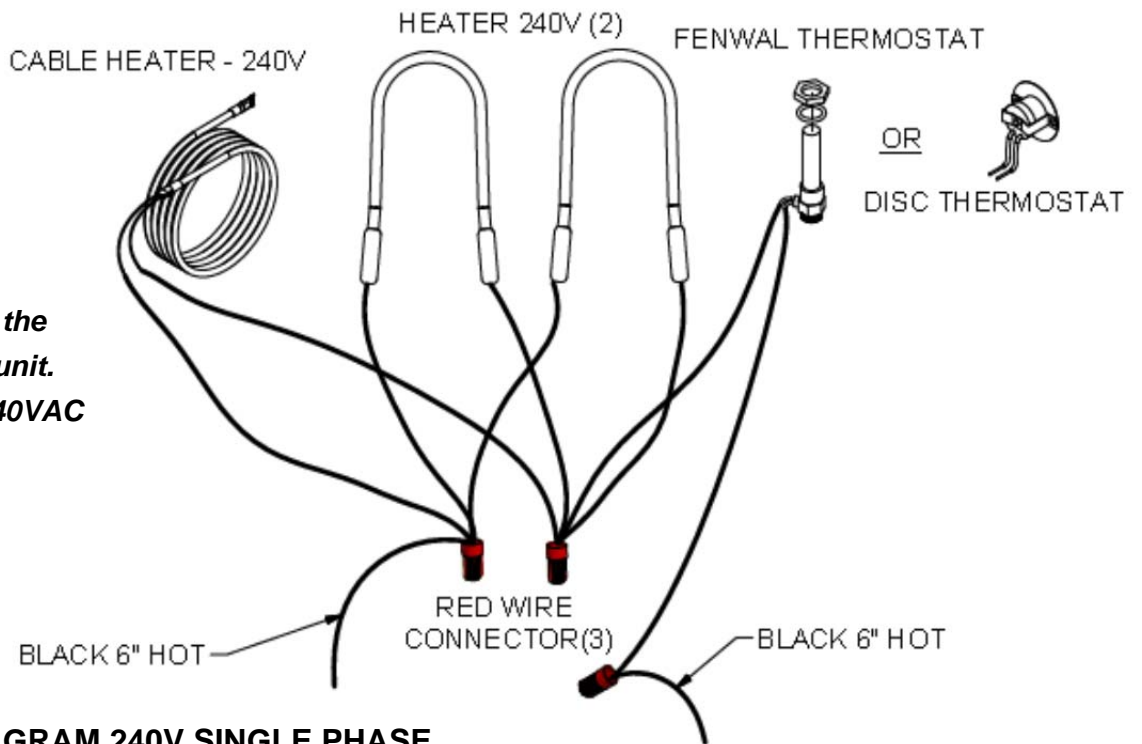

**WIRING DIAGRAM 240V SINGLE PHASE**

**WARNING: ANY ELECTRICAL SERVICE MUST BE INSTALLED AND MAINTAINED BY A QUALIFIED ELECTRICIAN.**

**WARNING: DISCONNECT POWER IF THE WATER SUPPLY IS TO BE SHUT OFF FOR AN EXTENDED AMOUNT OF TIME. FAILURE TO TURN OFF POWER CAN RESULT IN DAMAGE TO THE WATERING FOUNTAIN.**

**WARNING: THIS INSTALLATION MUST BE MADE AND MAINTAINED IN STRICT CONFORMITY WITH NATIONAL/LOCAL PLUMBING CODES AND NATIONAL/LOCAL ELECTRICAL CODES (CSA IN CANADA). THE APPLICABLE PROVISIONS OF THESE CODES TAKE PRECEDENT. FAILURE TO MAKE AND MAINTAIN ALL INSTALLATIONS PROPERLY MAY RESULT IN LOSS OF LIVESTOCK, PERSONAL INJURY, OR DEATH.**

**NOTE:** *National/Local electrical codes may require livestock waterers installed in feedlots in open feeding area to be grounded by a separate stranded copper grounding conductor or at least no.6 AWG terminating at a point where the branch circuit receives its supply. Check with local inspection authorities.*

J. **Disc Thermostat** – The disc thermostat is mounted in a bracket under the trough, which allows it to be moved relative to the heater. To ease movement of thermostat turn ¼ turn. To lock in position after adjustment turn ¼ turn back. **As the thermostat is moved toward the heater, the water temperature in the trough is lowered.** The best location is determined by checking the trough temperature several times during the heating season.

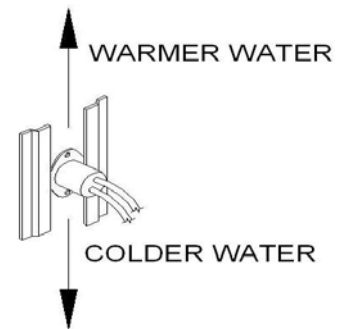

K. **Float Adjustment** – To access the float in the EcoFount the lid will need to be unlocked and then hinged open. Be sure to not lean on lid while it is open as this can damage the watering fountain. Insert the drain plug firmly into the drain hole in the trough. Open water-supply shut-off valve, check for and fix any leaks. Adjust float for a water depth of 1 to 2 inches below the top of the overflow pipe by adjusting the wing-nut on the float arm.

L. **Install Side Access Panel and Close Lid**– Once all water line connections have been checked for leaks and electrical hook-up is complete, the side access door may be installed. With the valve functioning properly and the water level set at the proper level, you may close and lock down the lid.

M. **Seal the Base** - After the unit is completely installed, apply a bead of caulking around the base of the fountain to ensure no wind enters through the base of the unit.

**NOTE:** *Sealing the bottom of the unit from cold air is an important aspect of the unit's thermal performance.*

N. **Children Should Be Supervised To Ensure That They Do Not Play With The Appliance** – This appliance is not intended for use by persons (including children) with reduced physical, sensory or mental capabilities, or lack of experience and knowledge, unless they have been given supervision or instructions concerning use of the appliance by a person responsible for their safety.

O. **Cleaning Your Fountain** – To clean your watering fountain you will need a good stiff bristled brush. Open the cover then brush the tank to remove any build-up. Remove the overflow plug that is located in the trough to drain out the water and debris. You can shut off the water with the shut-off valve located under the unit or by holding the float in the up position. After the water and debris has drained reinstall the overflow plug and let the tank refill. Now is a good time to readjust the float if needed. Close on lock down cover and you are done.

## Ritchie Valves

Ritchie valves come in three pressure ratings - green for high supply line pressure, red for moderate supply pressure, and white for low pressure applications. Your individual situations may require a change from the standard valve supplied with your fountain, see your Ritchie Dealer if this is needed.

**NOTE:** *If water pressure is over 60 psi, and if the valve does not shut off, a pressure-reducing valve may be needed.*

1/2"	Part #	GPM	Pressure Range
White	12574	4.8	Low, 5-40 psi. (34-275 kPa)
Red	12575	3.4	Moderate, 40-60 psi. (275-414 kPa)
Green	13597	1.45	High, 60-80 psi. (414-552 kPa)

## Hold Down Anchor Bolt Locations

**NOTE:** *Do not drill holes for anchors before location can be verified with unit*

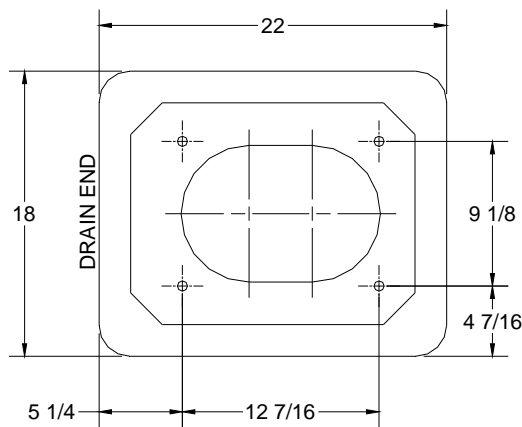

ECOFOUNT 1

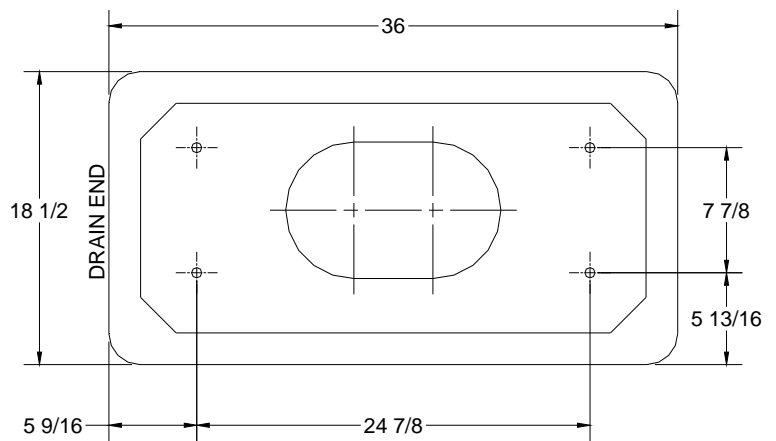

ECOFOUNT 2

## Trouble Shooting

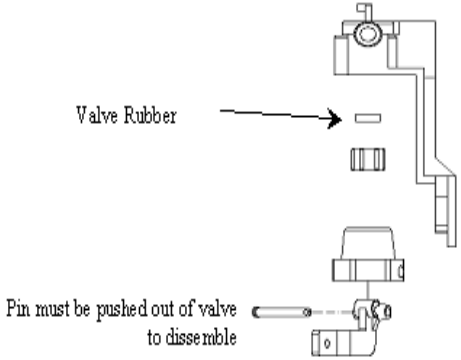
Problem	Solution	
Water in Trough Too Warm	Adjust thermostat to lower temperature (move closer to heater)	
	Check to see if thermostat has failed by contacts burning closed	
Ice in Trough	Check fuses or circuit breakers	
	Check all heating elements to make sure they are working and hot	
	Adjust thermostat to higher temperature (move away from heater)	
	Check for voltage from thermostat output	
	Check voltage to fountain with and without electrical load	
	Check that heaters are wired properly	
Valve Freezing	Check that cable heater is installed properly and fastened to water supply line and is working when heaters are hot	
	Check for missing or damaged insulation	
	Check for air gaps for wind penetrations	
Supply line Freezing	Check that the cable heater is uncoiled and fastened around valve, to supply line and is working when heaters are hot	
	Check that supply piping is centered in riser tube	
	Check that riser tube is free of water and mud that may freeze	
	Check that flexible hose does not touch side of casing or frame	
	Check casing for air leaks	
	Check for air gaps between casing and concrete floor	
Valve won't stop dripping	Check float adjustment. Check for waterlogged float, or float rubbing on side of valve compartment	
	<p>Disassemble valve and check for sand or scale in valve rubber. Also check valve orifice outlet for wear and damage. A screen or filter may be required with sandy or scaly water.</p>	 <p style="text-align: center;"><b>1/2" Valve</b></p> <p style="text-align: center;">Valve Rubber →</p> <p style="text-align: center;">Pin must be pushed out of valve to disassemble</p>
	<p>Turn valve rubber over and re-assemble</p>	
	Check for excessive water system pressure	
Low water flow	Check that valve inlet is not plugged or supply hose is not kinked	
	Check system pressure from supply hose by installing a tee and a pressure gauge directly in front of the valve to check pressure drop when valve is open. A severe pressure drop indicates a restriction or undersized supply system.	
	Check that shutoff valves are fully open	

# Ritchie Limited Warranty

Effective September 2012

Ritchie Industries, Inc. warrants its products to be free of defective materials and workmanship. Defective part(s) will be repaired or replaced at the option of Ritchie Industries. **This warranty specifically excludes all labor and shipping charges.**

This warranty does not apply to any appearance items, to any product whose exterior has been damaged or defaced, to any product that has been improperly installed, to any product subjected to misuse, abnormal service or handling, and to any products altered or repaired with other than original equipment or manufacturer's parts.

This warranty gives you specific legal rights, and you may also have other rights which vary from state to state.

All warranty claims must be processed through an Authorized Ritchie Dealer/ Distributor. **Proof of purchase is required. This warranty is not transferable.** The period of warranty begins at original date of purchase as follows:

## **Poly Units**

### **Base, top and ball closures**

10 year limited against manufacturing defect. 100% first five years, then declining 20% per year for the remaining five years.

## **Stainless Steel Units**

### **Stainless trough and stainless valve chamber frame:**

Ten years against manufacturing defect or corrosion. 100% all ten years.

### **Casing and cover:**

10 year limited against manufacturing defect. 100% first year, then declining 10% per year for the remaining nine years.

## **Component Parts**

### **All component parts, such as floats, valves, heating elements:**

One year from the date of purchase against manufacturing defect, 100%.