

OmniFount 2

Part # 16619

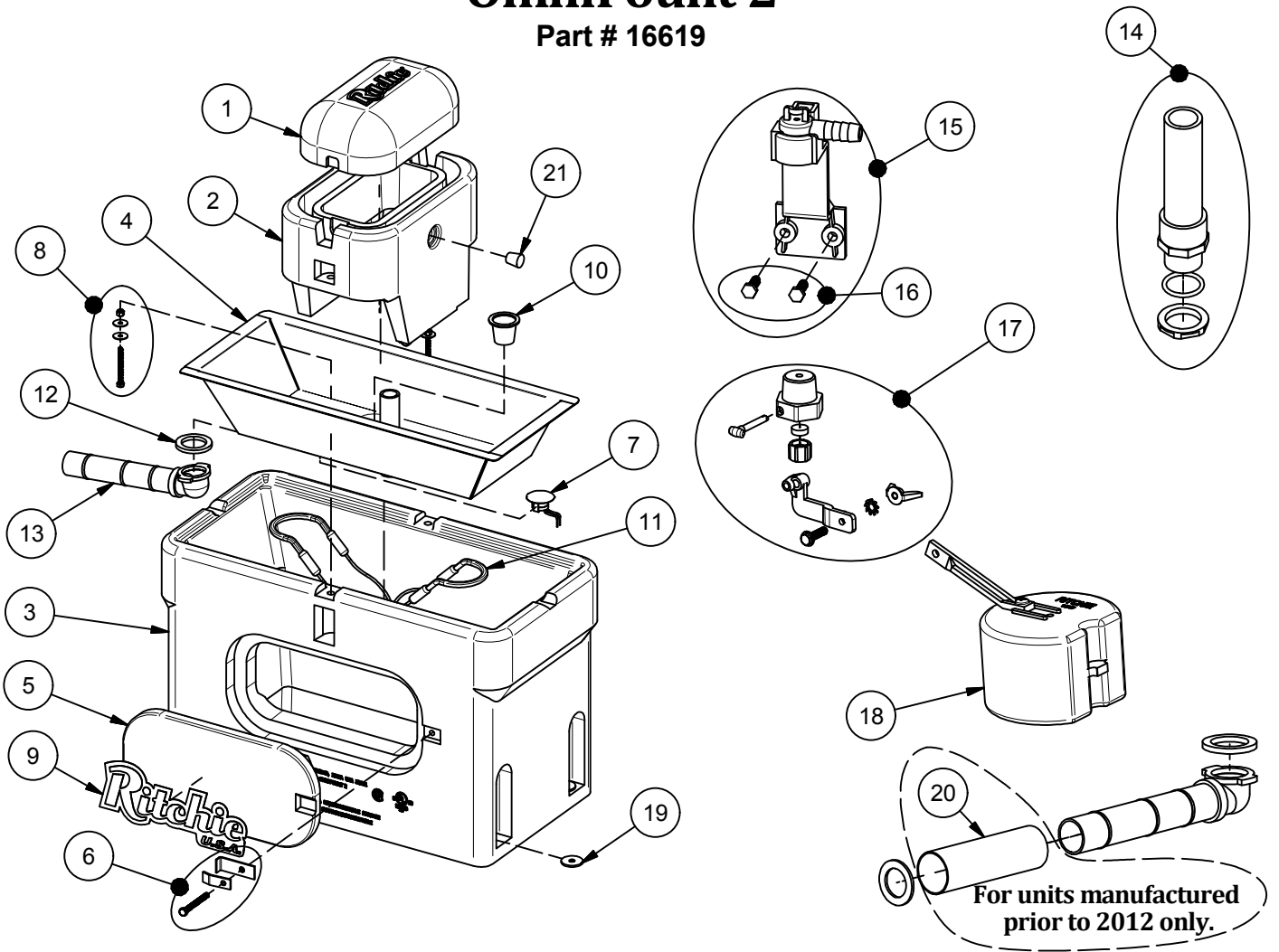

Item	Part #	Description	Qty	Item	Part #	Description	Qty
1	18424	Omni 2 Cover	1	15	11515	Valve Bracket 1/2" w/ Scrws pkg	1 pkg
2	18347	Omni 2 Frame pkg	1 pkg	16	18066	Screws Valve Bracket (6/ pkg)	1 pkg
	18348	Omni 2 Cover & Frame pkg	1 pkg	17	12575	Red Valve 1/2" pkg	1 pkg
3	16620	Omni 2 Casing	1	18	13613	Float with Short Arm pkg	1 pkg
4	16616	Omni 2 Trough	1 pkg	19	18318	Bolt Down Washer (4/pkg)	1 pkg
5	16621	Access Panel 6"x14"	1	20	17500	Drain Pipe Guard (Before 2012)	1
6	18147	Access Panel Hardware pkg	1 pkg	21	18633	Plug #3 - Water Channel (2/pkg)	1 pkg
7	11885	Disc Thermostat pkg	1 pkg	NS	13830	Cable Htr 120V 48W (1/pkg)	1 pkg
8	18266	Frame Bolt,nut&wshr SS(3/pkg)	1 pkg	NS	16627	Omni 2 Accessory pkg	1 pkg
9	18653	Ritchie Decal 12" (1/pkg)	1 pkg	NS	16523	Seal Foam 1/4"x3/4"x25' Roll	1
10	18628	Drain Plug (2/pkg)	1 pkg	NS	14866	Seal Foam 1/2"x3/4"x10' Roll	1
11	14150	Heater 120V 125W (1/pkg)	2 pkgs				
12	18075	Drain Washer (6/pkg)	1 pkg		16844	OMNI 2 240V	
13	11471	Drain Pipe with Elbow	1	NS	16664	Heater 240V 200W (1/pkg)	2 pkgs
14	16866	Standpipe pkg	1 pkg	NS	16424	Cable Htr 240V 48W (1/pkg)	1 pkg