

# Installation Instructions

For

# Classic Equine<sup>®</sup>

---

P L A Y T O W I N<sup>™</sup>

## EZFOUNT

*Congratulations, you have just purchased the finest watering fountain on the market. This unit is built to give you excellent service when properly installed and maintained. Please follow instructions carefully. Read and understand all instructions before installing.*



Part # 24058  
12 July, 2021

## Fountain Installation Instructions

**A. Location** - Installing the fountain in a location that offers protection from the wind will enhance the performance of the unit. Livestock will tend to gather in a protected area, enticing them to drink more.

### **B. Mounting Options –**

1. **Option A** – If mounting the fountain on a concrete platform it should be at least 4” thick and large enough to accommodate the fountain. An additional 4” high step 18” out from each side of the unit will protect the unit from manure handling equipment, as well as discouraging animals from defecating in the fountain. Extending the platform provides animals a place to stand while drinking, consider the size of your animals when determining the dimensions of your platform. Slope the platform away from the fountain for drainage. A rough broom finish on the concrete surface provides better footing for animals.

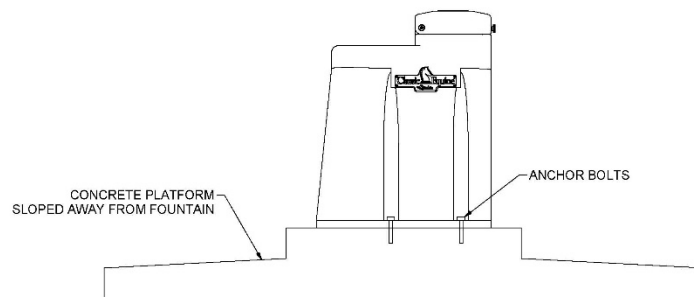

2. **Option B** – Filling with sand. **Two adults are required to complete this assembly.** Fill the fountain with up to 350 lbs of sand. Locate fountain in its final position and then roll it forward on to its top. With the fountain flipped over fill with sand and then press the red plug in place to seal hole. Using two adults flip the fountain back to its base and set into position.

**C. Hold-Downs** - Your fountain has four built-in hold-down locations to anchor your unit securely to the concrete pad. The use of 3/8” x 5” stainless steel expansion anchor bolts (not included) is recommended for concrete installations. Anchor bolts are available from Ritchie in a two pack, part # 16555. Fender washers are supplied for use with anchors.

**D. Hose Connection** – Connect hose to supplied connection. Be sure to place hose out of the reach of animals.

**E. Drain Plug** – Install pre-assembled drain plugs from inside of trough. Plugs should be pushed in flush to prevent accidental removal by animals. Wetting the plug can aid proper installation.

**F. Float Adjustment** – Adjust float for a water depth of 2 inches below top of trough using the thumbscrew or wing nut.

**G. High Water Pressure** - If water pressure is very high, and the valve does not shut off, a pressure-reducing valve may be needed, Ritchie part # 18649. Your individual situations may require a change from the standard valve supplied with your fountain.

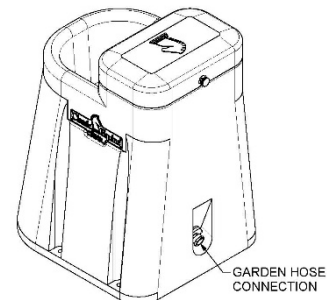

## Trouble Shooting

Problem	Solution
Valve won't stop dripping	a) Check float adjustment. Ensure float moves freely.
	b) Disassemble valve and check for sand or scale in valve rubber
	c) Turn valve rubber over and re-assemble. See below.
	d) Check for excessive water system pressure.
Low Water Flow	a) Check that valve inlet is not plugged or supply hose is not kinked.
	b) Check system pressure from supply hose by installing a tee and pressure gauge in front of the valve to check pressure drop when valve is open. A severe pressure drop indicates a restriction or undersized supply system.
	c) Check that shut off valves are fully open.

### 1/2" Valve:

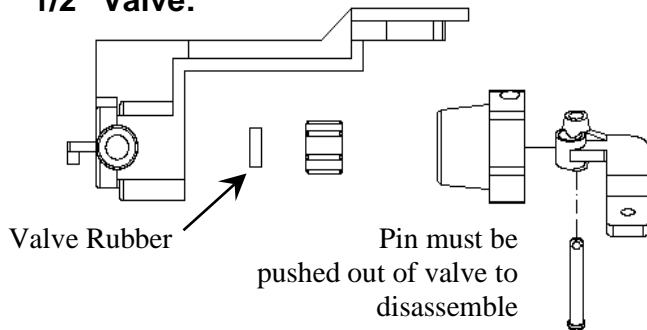

## Ritchie Limited Warranty

Effective June 2021

Ritchie Industries, Inc. warrants its products to be free of defective materials and workmanship. Defective part(s) will be repaired or replaced at the option of Ritchie Industries. **This warranty specifically excludes all labor and shipping charges.**

This warranty does not apply to any appearance items, to any product whose exterior has been damaged or defaced, to any product that has been installed improperly, to any product subjected to misuse, abnormal service or handling, and to any products altered or repaired with other than original equipment or manufacturer's parts.

This warranty gives you specific legal rights, and you may also have other rights which vary from state to state.

All warranty claims must be processed through an Authorized Ritchie Dealer/ Distributor. **Proof of purchase is required. This warranty is transferable.** The period of warranty begins at original date of purchase as follows:

### Poly Units

#### Base, top and ball closures

10 year limited against manufacturing defect. 100% first five years, then declining 20% per year for the remaining five years.

### Stainless Steel Units

#### Stainless trough and stainless valve chamber frame:

Ten years against manufacturing defect or corrosion. 100% all ten years.

#### Casing and cover:

10 year limited against manufacturing defect. 100% first year, then declining 10% per year for the remaining nine years.

### Component Parts

#### All component parts, such as floats, valves, heating elements:

One year from the date of purchase against manufacturing defect, 100%.

# Classic Equine

## EZFOUNT

Part # 18710

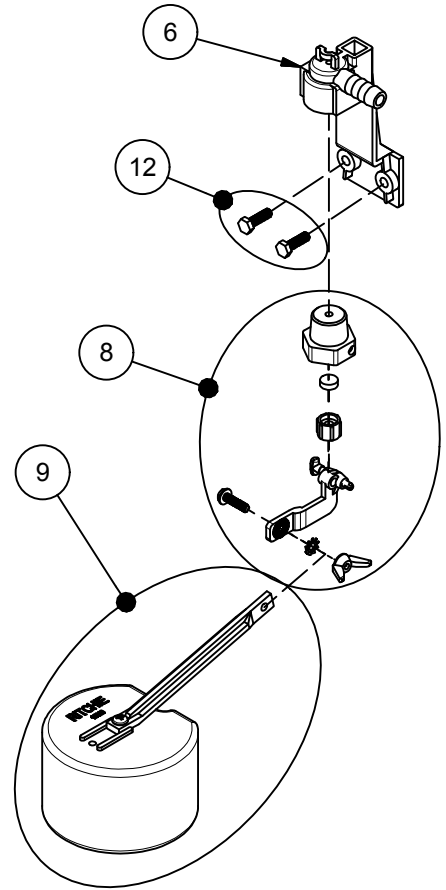
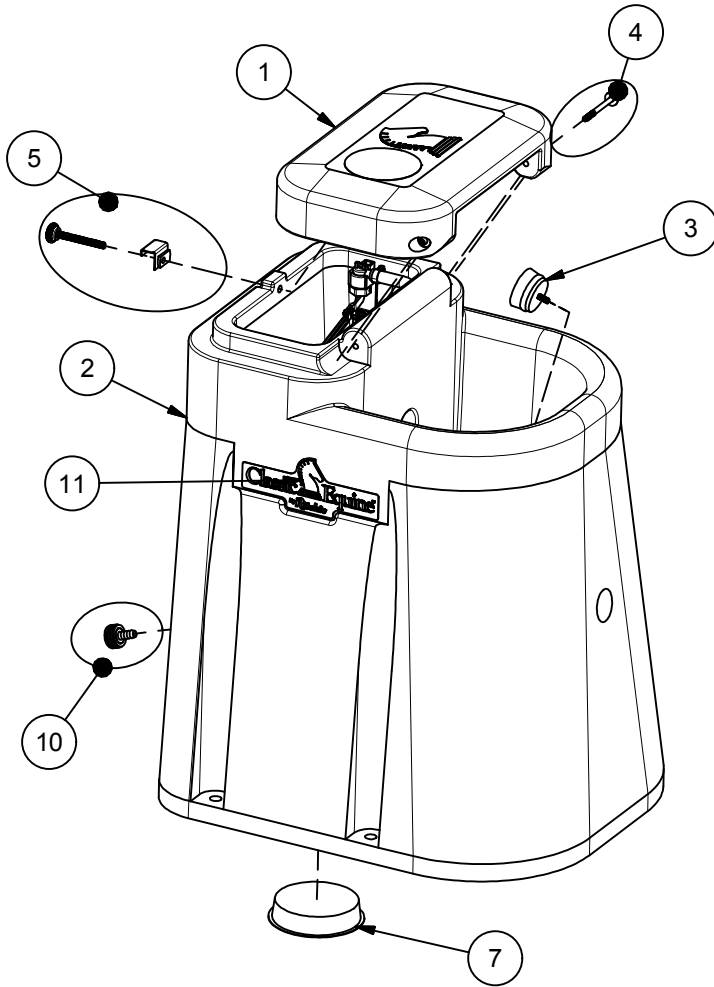

Item	Part #	Description	Qty	Item	Part #	Description	Qty
1	18712	EZFOUNT Cover	1	9	12836	Float with Long Arm pkg	1 pkg
2	18714	EZFOUNT Base	1	10	18717	EZFOUNT Hose Adpt. Pkg	1 pkg
3	18219	Plug #11 Pkg	1 pkg	11	18719	Classic Equine Logo pkg (2/pkg)	1 pkg
4	18716	Classic Equine Hinge Bolt Pkg	1 pkg	12	18709	Screws #10 x 1 pkg (4/pkg)	1 pkg
5	18718	Cover Latch Hardware pkg	1 pkg	NS	15930	Hose Clamp 7/8" SS (5/pkg)	1 pkg
6	11515	Valve Bracket pkg	1 pkg	NS	18613	Adapter 1/2" x 3/8" HB	1 pkg
7	18727	Cap Pkg (2/pkg)	1 pkg	NS	18715	EZFOUNT Accessory pkg	1 pkg
8	12575	Red Valve 1/2" pkg	1 pkg				