

Installation Instructions for



WaterMaster 800

Congratulations, you have just purchased the finest watering fountain on the market. This unit is built to give you excellent service when properly installed and maintained. Please follow instructions carefully. Read and understand all instructions before installing

Ritchie Industries, Inc.
800-747-0222
www.ritchiefount.com

Part # 24160
June 10, 2021

    @RitchieWaterers

WaterMaster 800 Fountain Installation Instructions

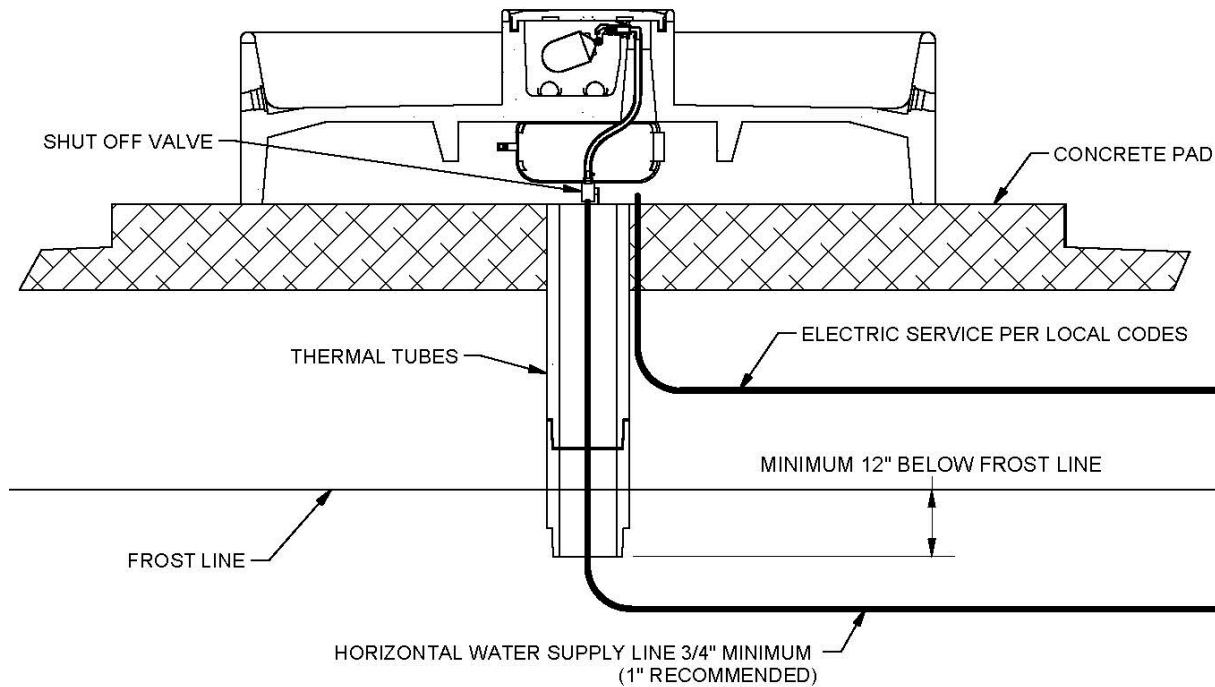

WaterMaster 800 fountains may need to use supplemental heat. Please see Supplemental Heat in the Special Situations section of this manual, page 4 for specific recommendations.

A. Location - Putting the fountain in a location that offers protection from the wind will enhance the performance of the fountain. Livestock will tend to gather in this protected area, enticing them to drink more. If possible, the side that supply line enters the fountain should be opposite of prevailing winter wind to give additional protection to the supply line.

B. Water Supply Line – The horizontal underground water line should be sized to account for pressure drop, relating to distance, at least 3/4" (1" recommended) in diameter and 1' below normal frost depth. A 3/4" (1" recommended) vertical supply pipe is recommended for the WaterMaster 800. A shut-off valve may be installed under the fountain for easier servicing. For optimum serviceability a stop and waste valve can be installed below frost level to drain water back when unit is not in use. A shutoff valve or stop and waste valve can be obtained from your local plumber. Flush water supply line thoroughly before connecting to fountain.

C. Riser Tube – Install a riser tube around pipe to provide room for plumbing and to accommodate optional shut-off valve. Ensure that the water supply line is centered in the riser tube. Do not add any insulation in the riser tube, as it provides a path for frost. For optimum water line protection, use the 12” outside diameter insulated Ritchie Thermal Tube. Use whatever combination of Thermal Tubes is required to reach at least 1' below frost line.

Ritchie Thermal Tubes	
18158 - 1' top section	16612 - 4' top section
16417 - 2' top section	16416 - 2' extension

NOTE: *The supply line touching the riser tube is the most common cause of the supply line freezing. Do not surround the supply line with insulation, wood, or other foreign material. Any foreign material in the tube may cause frost to migrate to the supply line causing it to freeze.*

D. Electrical Connection (Optional): Although WaterMaster 800 fountains are insulated, in cold climates supplemental heat will be required. If electricity is available, it is a good management decision to run the electrical line for future use.

WARNING: ANY ELECTRICAL SERVICE MUST BE INSTALLED AND MAINTAINED BY A QUALIFIED ELECTRICIAN IN COMPLIANCE WITH LOCAL CODES.

E. Mounting Platform – A concrete platform should be provided for all fountains. It should be at least 4” thick and large enough to accommodate fountain. An additional 4” high step 18” out from each side of the unit will protect the unit from manure handling equipment, as well as discouraging animals from defecating in the fountain. Extending the platform provides animals a place to stand while drinking, consider the size of your animals when determining the dimensions of your platform. Slope the platform away from the fountain for drainage. A rough broom finish on the concrete surface provides better footing for animals.

F. Preparing the Bottom - Apply the foam weather stripping to the bottom of the unit, around the outside edge of the fountain.

G. Hold-Downs - WaterMaster 800 Fountains have mounting pockets molded into the base. Use of Ritchie stainless steel anchor bolts (not included) is recommended for concrete installations. Anchor bolts are available from any Ritchie authorized dealer, in packages of two, part # 16555.

Place fountain on the concrete platform over the riser tube so the supply hose is centered in riser tube. Mark anchor bolt locations at each pocket location. Set fountain aside to drill anchor bolt holes.

H. Position Fountain - Connect hose to the top of the supply line, or the customer supplied shutoff valve at the top of the concrete. Set the fountain in position on the concrete pad to inspect positioning of the installation.

Once you have verified the positioning of the fountain, install, and tighten down anchor bolts. Use the large washers provided to hold unit down. Tighten hold down anchors tight, but do not over tighten as this could damage the plastic feet.

I. Assemble Valve – Follow the steps to assemble the high pressure valve included with your waterer.

1. Insert valve rubber into the valve rubber retainer.
2. Attach float arm to float as shown in diagram. The raised emboss on top of float should be orientated as shown.
3. Screw thumb screw into cam arm. To adjust water level, tighten thumb screw to lower, loosen thumb screw to raise.
4. Insert the valve rubber retainer into the valve body with the valve rubber up. Align the cam arm to the valve body and insert first pin.
5. Align the float arm and attached float to the cam arm and insert second pin.

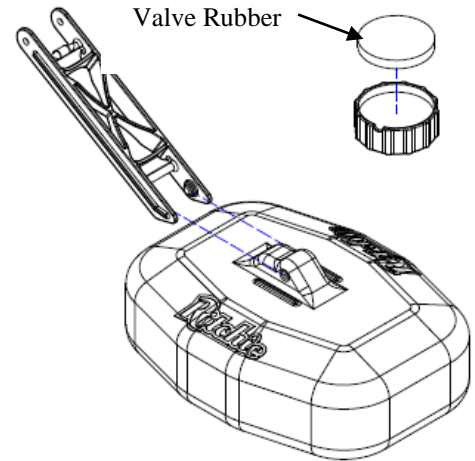

J. Valve Mounting – After fountain is in proper place, place rubber washer, plastic washer and nut on bulkhead, cut hose to proper length and connect to valve bracket with hose clamp. Place the valve and bracket assembly in the slot provided in the wall of the valve chamber and tighten nut.

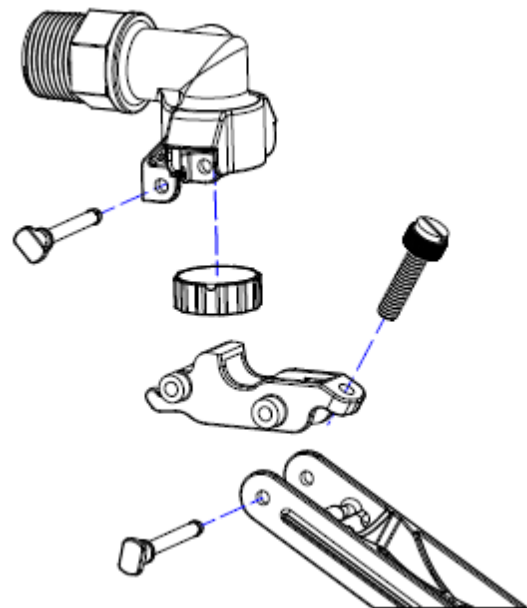

K. Seal the Base – After the unit is completely installed, apply a bead of caulking around the base of the fountain to ensure no wind enters through the base of the unit.

NOTE: *Sealing the bottom of the unit from cold air is an important aspect of the unit's thermal performance.*

L. Drain Plug – Install pre-assembled plugs from the inside of the trough. Wetting the plug can aid in installation. Tighten wing nut to secure.

M. Float Adjustment - Turn on water supply, check for and correct any leaks, and adjust float levels. For the WaterMaster 800, the depth should be about 2 inches below the overflow.

N. Water Seal Drain – For models DM 8 install the small drain plug into the drain hole in the water seal trough around the valve chamber seal. This plug may be removed during non-freezing periods to allow water seal to drain.

O. Install Cover – Fill the water seal groove with liquid to seal against air infiltration before assembling. Drop in the valve chamber cover. Note: Serial number or date code is found on underneath side of top red valve cover.

Tip: *You may use vegetable oil to fill the water seal groove, or coat the inside of the groove with baking pan coating spray before filling with water to make the cover easier to remove and reinstall during freezing weather. For areas with high evaporation, using vegetable oil may be necessary.*

P. Cleaning Your Fountain – To clean your watering fountain you will need a good stiff bristled brush. Remove the cover then brush the water seal groove to remove any build-up then brush the tank. Remove the drain plug that is located at the end of the trough to drain out the water and debris. You can shut off the water with the shut-off valve located under the unit or by holding the float in the up position. After the water and debris has drained reinstall the plug and let the tank refill. Now is a good time to readjust the float if needed. Reinstall cover and you are done.

Special Situations

Non-Siphoning

The Ritchie WaterMaster 800 meets Grade A dairy non-siphoning guidelines.

Installation Variations

Incoming water temperature and pressure will vary, and will affect the performance of your fountain. Well water will be between 45° and 50°, but rural water from a water tower may be substantially cooler. Supplemental heaters and alternate valves are available for these variations.

Supplemental Heat

Both the valve chamber and the water supply line should be protected from freezing. To protect the valve chamber, immersion heaters should be placed flat on the bottom of the chamber. Ensure the heater and power cable does not interfere with the motion of the float. Self-regulating heat cables protect the supply line from freezing. Heat cables should wrap around the valve, and follow the supply line down into the riser tube. You may use nylon ties to anchor the cable to the supply line. Both immersion heaters and supply line heaters are thermostatically controlled, using power only when needed. Neither heater will get hot enough to melt the plastic of the fountain.

The higher power heaters should be used for larger troughs or where there may be electrical losses in the line due to long transmission distances. A stainless steel heater stand is included and should be used with the Ritchie 500W heater to protect the fountain in the event of water supply failure. The stand may be purchased separately to be used with any immersion heater, #16636.

Immersion Heaters			Self Regulating Heat Cable		
Part #	Volts	Watts	Part #	Volts	Watts
16311	120	250	16276	120	30
17960	240	250	16713	240	30
14158	120	500			

Ritchie Valves

The Ritchie WaterMaster 800 comes standard with our 3/4" yellow high pressure valve that is rated up to 110 psi. If water pressure is very high, and if the valve does not shut off, a pressure-reducing valve may be needed. Your individual situations may require a change from the standard valve supplied with your fountain.

WaterMaster 800

Part # 18820

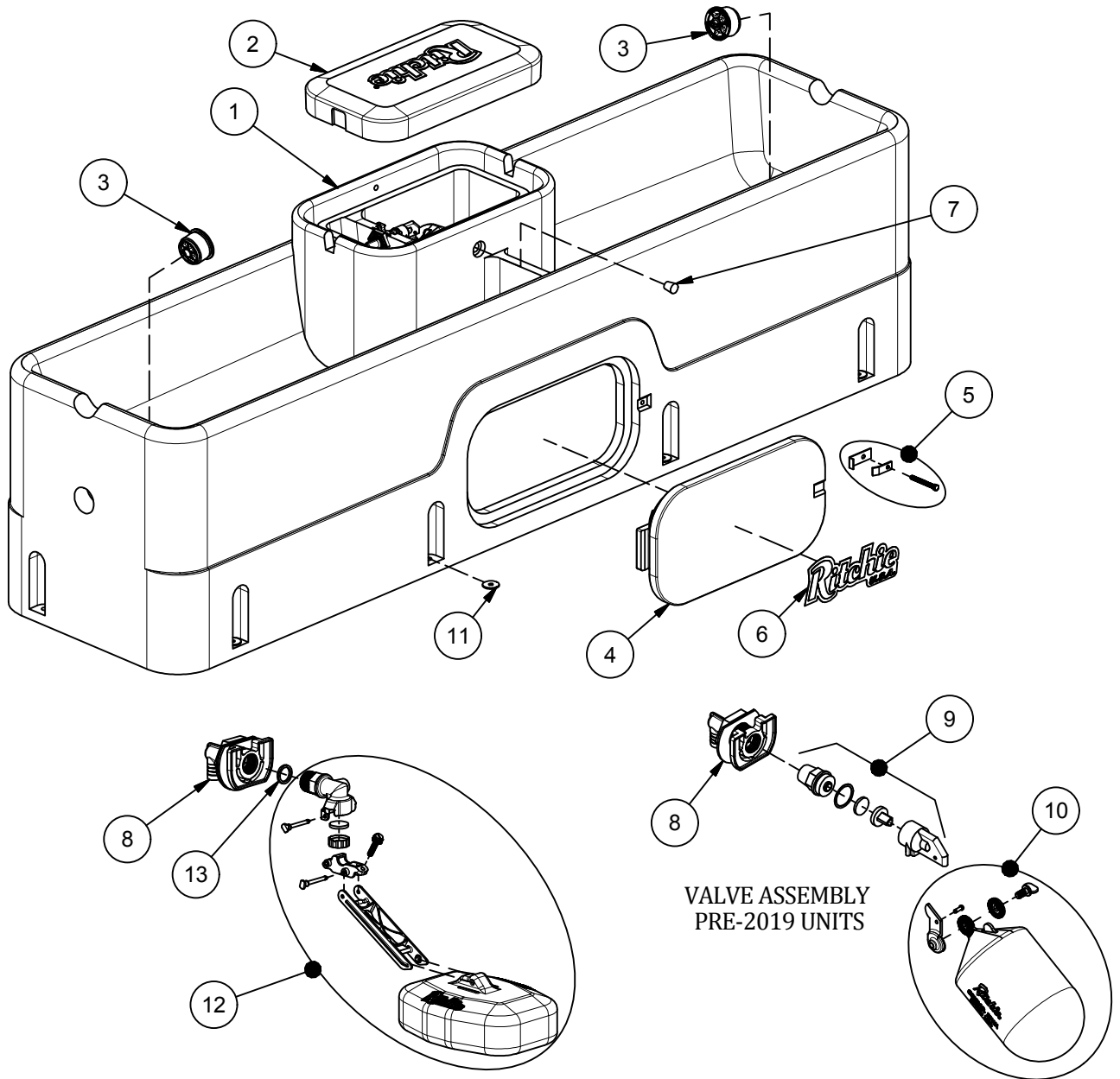

Item	Part #	Description	Qty	Item	Part #	Description	Qty
1	18823	WM 800 Base	1	10	18314	Float with Hardware pkg	1 pkg
2	18828	WM 800 Cover	1		18313	Hardware for Float pkg	1 pkg
3	18470	Drain Plug Ritchie 3"	2 pkgs	11	18318	Bolt Down Washer (4/pkg)	2 pkgs
4	16562	Access Panel 10" x 20"	1	12	18832	HP 3/4" Valve Assembly	1
5	18147	Access Panel Hardware Pkg	1 pkg	13	18475	O-Ring Valve Seal Pkg (4/pkg)	1
6	18653	Ritchie Decal 12" (1/pkg)	1 pkg	NS	14866	Seal Foam 10' Roll	3
7	18633	Plug #3 - Channel Plug	1 pkg	NS	15931	Hose Clamp 1" SS (5/pkg)	1 pkg
8	18838	HP Bracket Assy Pkg	1 pkg	NS	18614	Adapter 3/4" x 5/8" HB	1 pkg
9	16419	Green Valve 3/4" Female pkg	1 pkg	NS	18826	WM 800 Accessory pkg	1 pkg

Trouble Shooting

Problem	Solution
Water Freezing in the Valve or Supply Line	Make sure the fountain is sealed from wind between the concrete platform and bottom of unit
	Make sure water seal groove is filled with liquid
	Make sure supply line is properly installed: <ul style="list-style-type: none"> ◆ Riser tube with supply line centered, and air space between riser tube and supply line. Ritchie Thermal Tubes are recommended as they have optimum inside and outside diameter to maximize insulation ◆ Horizontal supply line is at least 1 foot below frost line
	If freezing continues, use supplemental heat or constant flow below freezing temperatures.
Low Water Flow	Check that valve inlet is not plugged or supply hose is not kinked.
	Check system pressure from supply hose by installing a tee and pressure gauge in front of the valve to check pressure drop when valve is open. A severe pressure drop indicates a restriction or undersized supply system.
	Check that shut off valves are fully open.
Valve won't stop dripping	Check float adjustment. Ensure float moves freely.
	Take valve apart and check for sand or scale in valve rubber See below.
	Turn valve rubber over and re-assemble. See below.
	Check for excessive water system pressure.

Ritchie Limited Warranty

Effective June 2021

Ritchie Industries, Inc. warrants its products to be free of defective materials and workmanship. Defective part(s) will be repaired or replaced at the option of Ritchie Industries. **This warranty specifically excludes all labor and shipping charges.**

This warranty does not apply to any appearance items, to any product whose exterior has been damaged or defaced, to any product that has been improperly installed, to any product subjected to misuse, abnormal service or handling, and to any products altered or repaired with other than original equipment or manufacturer's parts.

This warranty gives you specific legal rights, and you may also have other rights which vary from state to state.

All warranty claims must be processed through an Authorized Ritchie Dealer/ Distributor. **Proof of purchase is required. This warranty is transferable.** The period of warranty begins at original date of purchase as follows:

Poly Units

Base, top and ball closures

10 year limited against manufacturing defect. 100% first five years, then declining 20% per year for the remaining five years.

Stainless Steel Units

Stainless trough and stainless valve chamber frame:

Ten years against manufacturing defect or corrosion. 100% all ten years.

Casing and cover:

10 year limited against manufacturing defect. 100% first year, then declining 10% per year for the remaining nine years.

Component Parts

All component parts, such as floats, valves, heating elements:

One year from the date of purchase against manufacturing defect, 100%.