

Installation Instructions for



CattleMaster Series Fountains

Congratulations, you have just purchased the finest watering fountain on the market. This unit is built to give you excellent service when properly installed and maintained. Please follow instructions carefully. Read and understand all instructions before installing.

Ritchie Industries, Inc.
800-747-0222
www.ritchiefount.com

Part # 17873
2 November, 2021

    @RitchieWaterers

CattleMaster Series Installation Instructions

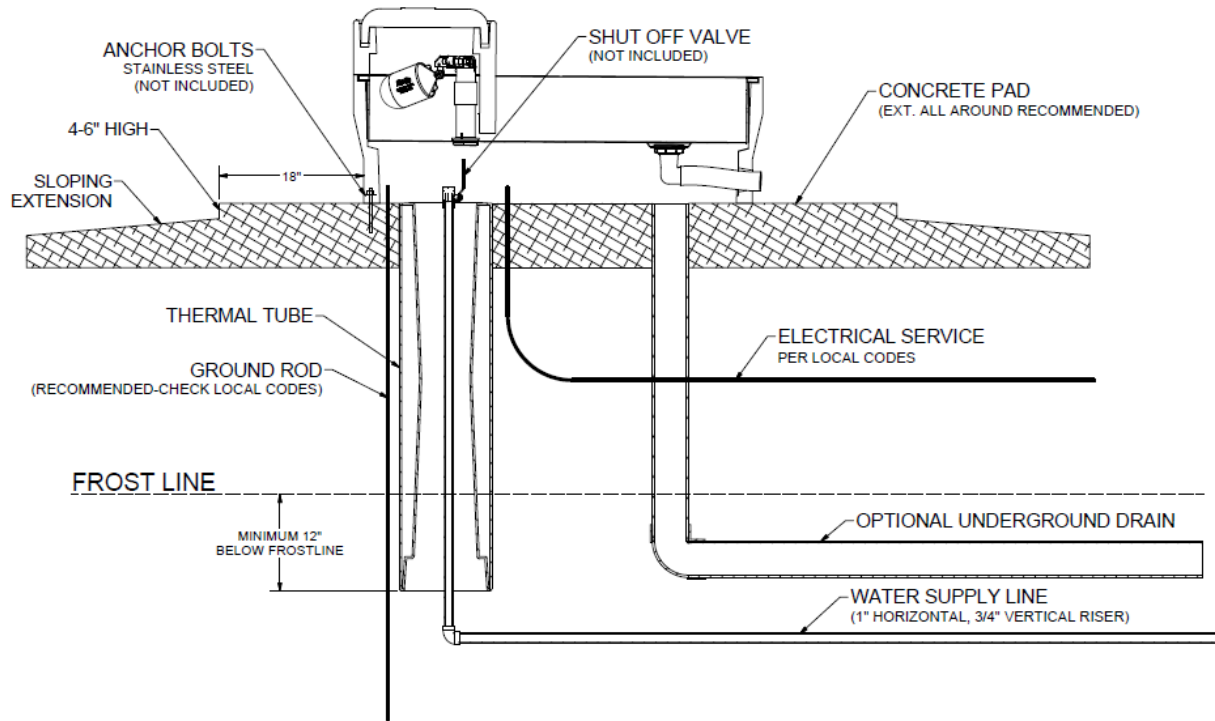

A. Location - Installing the fountain in a location that offers protection from the wind will enhance the performance of the fountain. Livestock will tend to gather in this protected area, enticing them to drink more. Access panel should be opposite of prevailing winter wind to give additional protection to the supply line.

B. Water Supply Line - Horizontal underground water line should be sized to account for pressure drop, relating to distance, and placed one foot below frost line. A one-inch vertical supply pipe is recommended. A shut-off valve should be installed under fountain to allow for easier servicing. For optimum serviceability, a stop and waste valve can be installed below frost level to drain water when unit is not in use. Vertical supply line must be centered in riser tube to provide an air space between the line and frozen ground outside of tube. Flush water supply line thoroughly before connection to fountain. Water supplies with foreign material such as sand, rust, etc. may require a filter to keep fountain valve working properly.

C. Electric Supply – It is generally most cost effective to run your electrical supply line at the same time you are trenching for your water supply.

Item No.	Description	Watts	Amps
18248	CM480 120V	548W	4.6A@120V
18235	CM840 120V	1048W	8.7A@120V
18700	CM10T 120V	1048W	8.7A@120V
18252	CM1440 120V	1298W	10.8A@120V

Item No.	Description	Watts	Amps
18251	CM480 240V	648W	2.7A@240V
18243	CM840 240V	948W	4A@240V
18701	CM10T 240V	948W	4A@240V
18255	CM1440 240V	948W	4A@240V

D. Riser Tube - Install a riser tube and extend it at least one foot below frost line or down to horizontal underground water line. For optimum water line protection, use the 12" diameter insulated *Ritchie Thermal Tube*, part numbers and sizes are shown to the right. Tube opening must be kept clear.

Ritchie Thermal Tube	
Part #	Description
18158	1' Top Section
16417	2' Top Section
16612	4' Top Section
16416	2' Extension

NOTE: *The supply line touching the riser tube is the most common cause of the supply line freezing. Do not surround the supply line with insulation, wood, or other foreign material. Any foreign material in the tube may cause frost to migrate to the supply line causing it to freeze.*

E. Mounting Platform - A concrete platform must be provided for all fountains. Use a minimum of 4" thick, (6" recommended thickness), large enough to accommodate fountain, and additional 4" step (on top of the platform) extending 18" out from each side of the unit. This will protect the unit from manure handling equipment, as well as discouraging animals from defecating in the fountain. Extending the platform provides animals a place to stand while drinking, consider the size of your animals when determining the dimensions of your platform. The concrete step and platform should slope away from the fountain for drainage and should be flush with the top of the thermal tube. A rough broom finish to concrete surface provides better footing for livestock.

F. Preparing the Bottom - Apply the provided foam weather stripping to the bottom of the unit, along the outside edge of the fountain.

G. Anchoring Fountain - CattleMaster Fountains have mounting pockets molded into the base. Use of Ritchie part #16555, stainless steel anchor bolts (not included), is recommended.

Once you have verified the positioning of the fountain, drill, install, and tighten down anchor bolts. Use the large washers provided to hold unit down. Tighten hold down anchors tight, but do not over tighten as this could damage the plastic feet. *NOTE: Do not drill holes for anchors before location can be verified with unit.*

H. Hose Connection – Remove side panels and cover. Pull the bottom of the hose to the shut-off valve at the top of the concrete. Leaving enough slack to be able to pull the valve assembly from the standpipe, cut hose to proper length. Slip hose end on barb fitting and attached with hose clamp. Hose should not touch insulation or outside surface of fountain. Clamps and fittings are furnished to secure connections.

I. Cable Heater – Uncoil cable heater and loop around the valve. Attach the remaining part of the cable heater to the water supply, as far down the riser tube as possible with the cable twist ties provided. This heater is water tight, but should not be immersed in water. Heater may cross over itself, but should not be tightened at those locations.

CAUTION: Installation must not cause any strain on heater wiring connections. Avoid heater damage caused by hot spots due to its leads lying close to each other. Also, do not wrap additional insulation around heater.

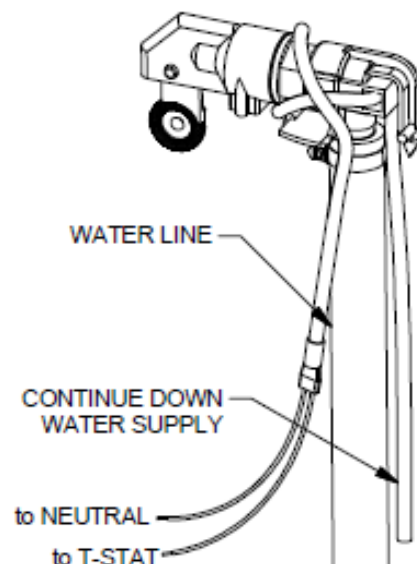

J. Electrical Connection - The electrical installation should be made and maintained by a qualified electrician conforming to national and local codes. A means for disconnection must be incorporated in the fixed wiring in accordance with the wiring rules. A suitable fuse or circuit breaker with properly sized wire must protect the 3-wire power to the fountain. For wiring connections, see wiring diagram.

WARNING: ANY ELECTRICAL SERVICE MUST BE INSTALLED AND MAINTAINED BY A QUALIFIED ELECTRICIAN.

WARNING: DISCONNECT POWER IF THE WATER SUPPLY IS TO BE SHUT OFF FOR AN EXTENDED AMOUNT OF TIME. FAILURE TO TURN OFF POWER CAN RESULT IN DAMAGE TO THE WATERING FOUNTAIN.

WARNING: THIS INSTALLATION MUST BE MADE AND MAINTAINED IN STRICT CONFORMITY WITH NATIONAL/LOCAL PLUMBING CODES AND NATIONAL/LOCAL ELECTRICAL CODES (CSA IN CANADA). THE APPLICABLE PROVISIONS OF THESE CODES TAKE PRECEDENT. FAILURE TO MAKE AND MAINTAIN ALL INSTALLATIONS PROPERLY MAY RESULT IN LOSS OF LIVESTOCK, PERSONAL INJURY, OR DEATH.

NOTE: *National/Local electrical codes may require livestock waterers installed in feedlots in open feeding area to be grounded by a separate stranded copper grounding conductor or at least no.6 AWG terminating at a point where the branch circuit receives its supply. Check with local inspecting authorities.*

K. Fenwal Thermostat – The adjustable range of the Fenwal Thermostat is from 0° F (-18° C) to 100° F (38° C). The thermostat is not preset at factory.

To adjust the thermostat to the desired temperature, first fill the trough to proper water level then check the water temperature with a thermometer. The next morning, check the water temperature again. If the water is warmer than desired, turn the thermostat down (clockwise). If there is ice forming on the surface of the water, turn the thermostat up (counter clockwise). Only slight adjustments should be made to the thermostat at any time. A 1/16 turn on the thermostat will change the water temperature 7° F (4° C). The most economical temperature for the trough is 44° F (7° C).

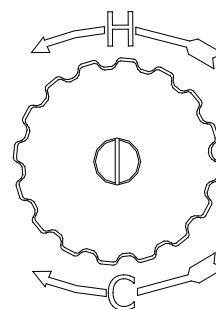

L. Seal the Base - After the unit is completely installed, apply a bead of caulking around the base of the fountain to ensure no wind enters through the base of the unit.

NOTE: *Sealing the bottom of the unit from cold air is an important aspect of the unit's thermal performance.*

M. Drain Plug – Insert the drain plug firmly into the drain hole in the trough. The plug can be secured by tightening the wingnut at the center of the plug.

N. Water Seal Drain – Install the small drain plug into the drain hole in the water seal groove around the valve chamber seal. This plug may be removed during the non-freezing periods to allow the water seal groove to drain.

O. Float Adjustment – Open water-supply shut-off valve, check for and fix any leaks. Adjust float for a water depth of 2 inches below top of trough or overflow pipe by adjusting the thumbscrew. With the valve functioning properly and the water level set at the proper level, you may install the valve cover. The water seal groove

between the frame and valve cover must be filled with liquid to create a protective seal from cold winter air getting to the valve.

P. Install Side Access Panel – Once all water line connections have been checked for leaks and electrical hook-up is complete, the side access door may be installed.

Q. Children should be supervised to ensure that they do not play with the appliance – This appliance is not intended for use by persons (including children) with reduced physical, sensory or mental capabilities, or lack of experience and knowledge, unless they have been given supervision or instructions concerning use of the appliance by a person responsible for their safety.

R. Cleaning Your Fountain – To clean your watering fountain you will need a good stiff bristled brush. Remove the cover then brush the water seal groove to remove any build-up then brush the tank. Remove the plug that is located at the end of the trough to drain out the water and debris. You can shut off the water with the shut-off valve located under the unit or by holding the float in the up position. After the water and debris has drained reinstall the plug and let the tank refill. Now is a good time to readjust the float if needed. Reinstall cover and you are done.

Ritchie Valves

Ritchie valves come in two sizes and three pressure ratings – green for high supply line pressure, red for moderate supply pressure, and white for low-pressure applications. Differences in the size of trough also impacts valve choice. Although different pressure rated valves may be used in a fountain, each fountain will only accommodate one size and configuration of valve. Your individual situations may require a change from the standard valve supplied with your fountain, see your Ritchie Dealer if this is needed.

3/4"	Part #	GPM	Pressure Range
White	16697	33	Low, 5-40 psi (34-275 kPa)
Red	11101	20	Moderate, 40-60 psi (275-414 kPa)
Green	15377	16.5	High, 60-80 psi (414-552 kPa)

NOTE: *Maximum inlet water pressure for each valve is shown above. If water pressure is extremely high, and if the valve does not shut off, a pressure-reducing valve may be needed.*

Product Specifications

Product Name	CM480	CM480	CM10T	CM1440
Part #	18248	18235	18700	18252
Drink Height - <i>in/cm</i>	16/41	16/41	25/64	16/41
Width - <i>in/cm</i>	23.5/59.7	23.5/59.7	32/81	23.5/59.7
Length - <i>in/cm</i>	51/129.5	86/218.4	120/305	146/370
Shipping Weight - <i>lbs/kg</i>	90/41	123/56	235/107	186/84
Operating Capacity - <i>gal/liter</i>	20/76	35/133	50/189	60/227
Herd Capacity - <i>head</i>	200 beef, 100 dairy	300 beef, 150 dairy	400 beef, 200 dairy	475 beef, 240 dairy

Trouble Shooting

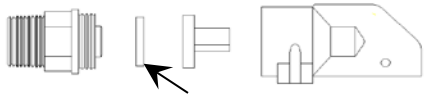
Problem	Solution	
Water in Trough Too Warm	Adjust thermostat to lower temperature	
	Check to see if thermostat has failed by contacts burning closed	
Ice in Trough	Check fuses or circuit breakers	
	Check all heating elements to make sure they are working and hot	
	Adjust thermostat to higher temperature	
	Check for voltage from thermostat output	
	Check voltage to fountain with and without electrical load	
	Check that heaters are wired properly	
Valve Freezing	Check that cable heater is installed properly and fastened to water supply line and is working when heaters are hot	
	Check for missing or damaged insulation	
	Check for air gaps for wind penetrations	
Supply line Freezing	Check that the cable heater is uncoiled and fastened around valve, to supply line and is working when heaters are hot	
	Check that supply piping is centered in riser tube	
	Check that riser tube is free of water and mud that may freeze	
	Check that flexible hose does not touch side of casing or frame	
	Check casing for air leaks	
Valve won't stop dripping	Check for air gaps between casing and concrete floor	
	Check float adjustment. Check for waterlogged float, or float rubbing on side of valve compartment	
	Disassemble valve and check for sand or scale in valve rubber. Also check valve orifice outlet for wear and damage. A screen or filter may be required with sandy or scaly water	<p>3/4" Valve:</p> 
	Turn valve rubber over and re-assemble	
	Check for excessive water system pressure	
Low water flow	Check that valve inlet is not plugged or supply hose is not kinked	
	Check system pressure from supply hose by installing a tee and a pressure gauge directly in front of the valve to check pressure drop when valve is open. A severe pressure drop indicates a restriction or undersized supply system.	
	Check that shutoff valves are fully open	

WIRING DIAGRAM FOR HEATED UNITS

120V UNITS - SINGLE PHASE (3) WIRE CONNECTORS FIELD SUPPLIED

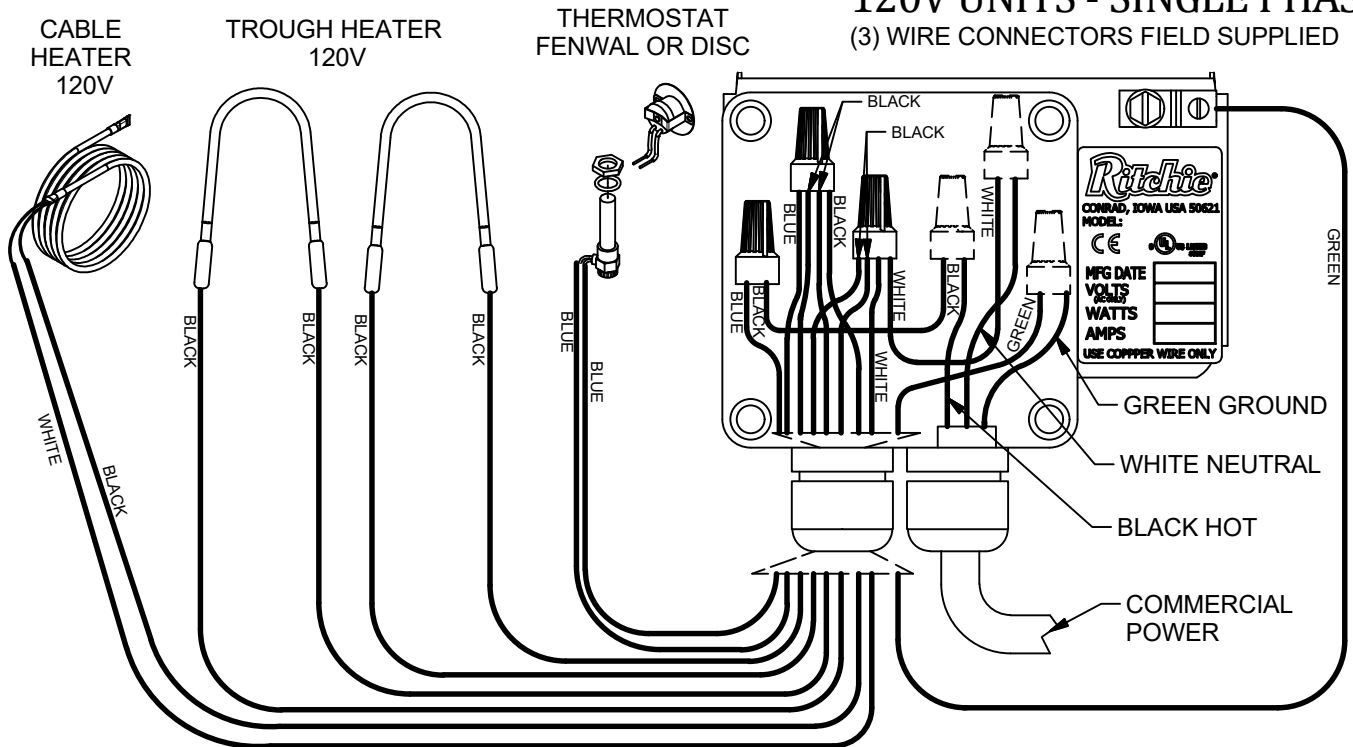

WARNING - CHECK NAMEPLATE FOR CORRECT VOLTAGE. ONLY CONNECT 120VAC TO 120V UNITS. WIRING DIAGRAM SHOWN WITH 2 HEATERS - QUANTITY MAY VARY

NOTE: Power cord may be supplied on select units to simplify installation. Use of a moisture resistant, exterior grade outlet is recommended in these units. Do not use extension cords.

240V UNITS - SINGLE PHASE (3) WIRE CONNECTORS FIELD SUPPLIED

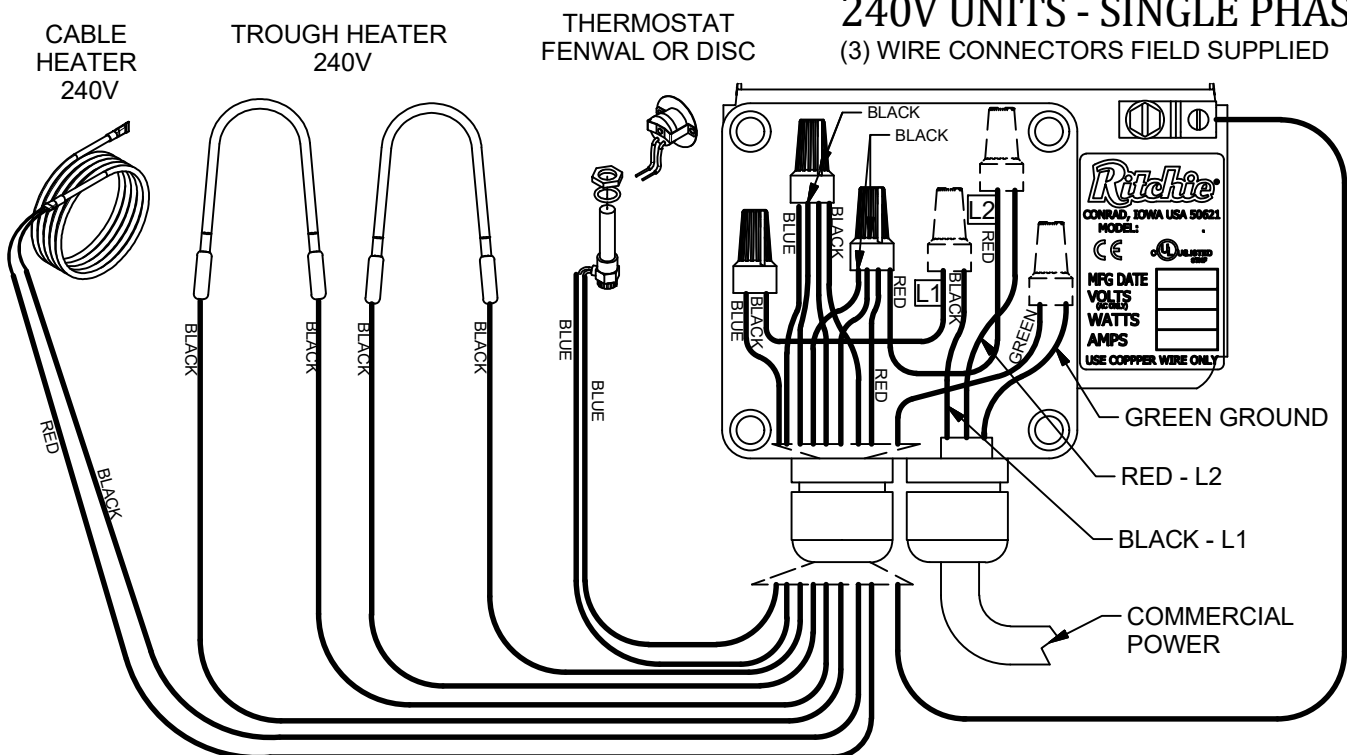

WARNING - CHECK NAMEPLATE FOR CORRECT VOLTAGE. ONLY CONNECT 230-240VAC TO 240V UNITS. WIRING DIAGRAM SHOWN WITH 2 HEATERS - QUANTITY MAY VARY

8/16/2021
Wiring-2021.dwg
TDU - Sheet: 1 of 1

CattleMaster 1440

Part # 18252

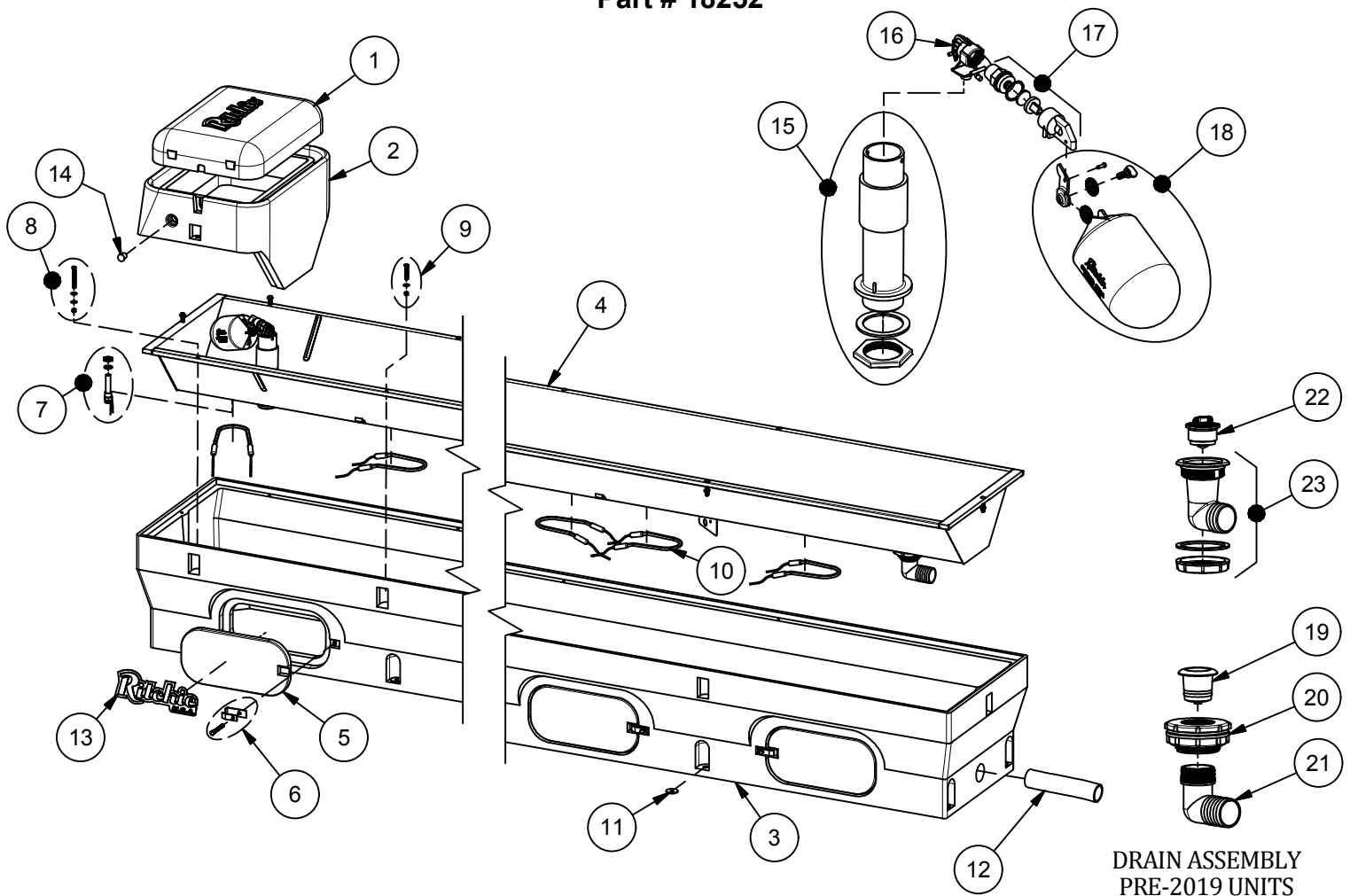

DRAIN ASSEMBLY
PRE-2019 UNITS

Item	Part #	Description	Qty	Item	Part #	Description	Qty
1	18428	CM Cover	1	15	18181	CM Standpipe pkg	1 pkg
2	18349	CM Frame pkg	1 pkg	16	11514	Valve Bracket 3/4" pkg	1 pkg
	18350	CM Cover & Frame pkg	1 pkg	17	15377	Green Male Valve 3/4" pkg	1 pkg
3	18659	CM 1440 Casing	1	18	18314	Float with Hardware pkg	1 pkg
4	16791	CM 1440 Trough pkg	1 pkg		18313	Hardware for Float pkg	1 pkg
5	16621	Access Panel 6"x14"	3	19	18338	CM Drain Plug pkg	1 pkg
6	18147	Access Panel Hardware pkg	3 pkgs	20	17679	CM Bulkhead fitting 2"	1
7	16534	Fenwal Thermostat SS pkg	1 pkg	21	17678	Drain Elbow Fitting	1
	18320	O-Ring Fenwal (6/pkg)	1 pkg	22	18849	Ritchie 2" Plug pkg	1 pkg
	18074	Nut Brass Fenwal (6/pkg)	1 pkg	23	18852	CM Drain Assembly pkg	1 pkg
8	18266	Frame Bolt & Wshr SS(3/pkg)	1 pkg	NS	12583	Valve Supply Line pkg	1 pkg
9	18265	Trough Bolt & Nut SS (5/pkg)	2 pkgs	NS	13830	Cable Htr 120V 48W (1/pkg)	1 pkg
10	11419	Heater 120V 250W (1/pkg)	5 pkgs	NS	18333	CM 1440 Accessory pkg	1 pkg
11	18318	Bolt Down Washer (4/pkg)	3 pkgs	NS	14866	Seal Foam 1/2"x3/4"x10' Roll	3
12	17677	Drain Tube 10"	1		18255	CM 1440 240V	
13	18653	Ritchie Decal 12" (1/pkg)	1 pkg	NS	11403	Heater 240V 300W (1/pkg)	3 pkgs
14	18633	Plug #3 - Water Channel (2/pkg)	1 pkg	NS	16424	Cable Htr 240V 48W (1/pkg)	1 pkg

CattleMaster 10T

Part # 18700

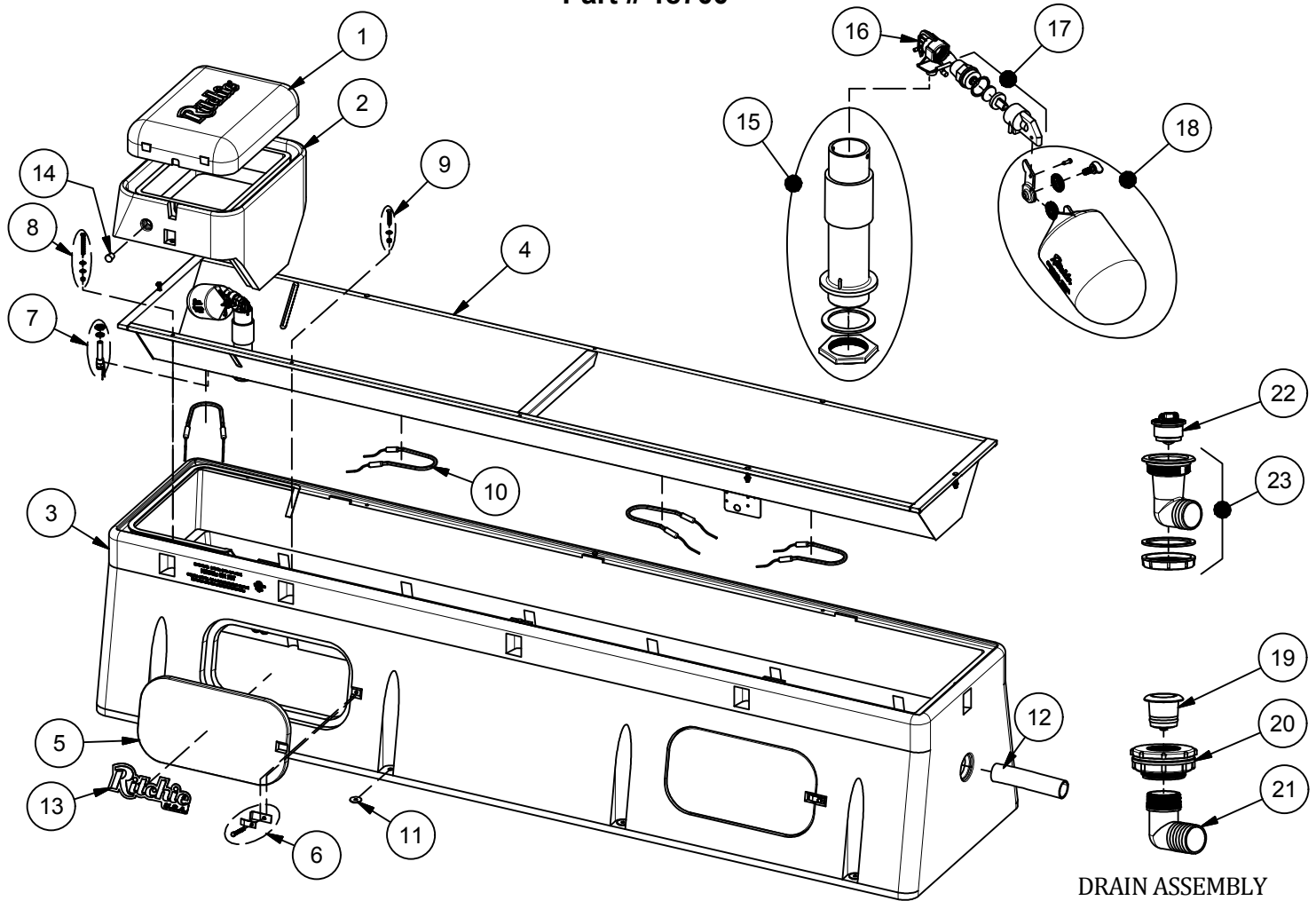

DRAIN ASSEMBLY
PRE-2019 UNITS

Item	Part #	Description	Qty	Item	Part #	Description	Qty
1	18428	CM Cover	1	15	18181	CM Standpipe pkg	1 pkg
2	18349	CM Frame pkg	1 pkg	16	11514	Valve Bracket 3/4" pkg	1 pkg
	18350	CM Cover & Frame pkg	1 pkg	17	15377	Green Male Valve 3/4" pkg	1 pkg
3	18698	CM 10T Casing	1	18	18314	Float with Hardware pkg	1 pkg
4	18697	CM 10T Trough	1 pkg		18313	Hardware for Float pkg	1 pkg
5	16562	Access Panel 10"x20"	2	19	18338	CM Drain Plug pkg	1 pkg
6	18147	Access Panel Hardware pkg	2 pkgs	20	17679	CM Bulkhead fitting 2"	1
7	16534	Fenwal Thermostat SS pkg	1 pkg	21	17678	Drain Elbow Fitting	1
	18320	O-Ring Fenwal (6/pkg)	1 pkg	22	18849	Ritchie 2" Plug pkg	1 pkg
	18074	Nut Brass Fenwal (6/pkg)	1 pkg	23	18852	CM Drain Assembly pkg	1 pkg
8	18266	Frame Bolt & Wshr SS(3/pkg)	1 pkg	NS	12583	Valve Supply Line pkg	1 pkg
9	18265	Trough Bolt & Nut SS (5/pkg)	1 pkg	NS	13830	Cable Htr 120V 48W (1/pkg)	1 pkg
10	11419	Heater 120V 250W (1/pkg)	4 pkgs	NS	18333	CM 10T Accessory pkg	1 pkg
11	18318	Bolt Down Washer (4/pkg)	2 pkgs	NS	14866	Seal Foam 1/2"x3/4"x10' Roll	2
12	17677	Drain Tube 10"	1		18701	CM 10T 240V	
13	18653	Ritchie Decal 12" (1/pkg)	1 pkg	NS	11403	Heater 240V 300W (1/pkg)	3 pkgs
14	18633	Plug #3 - Water Channel (2/pkg)	1 pkg	NS	16424	Cable Htr 240V 48W (1/pkg)	1 pkg

CattleMaster 840

Part # 18235

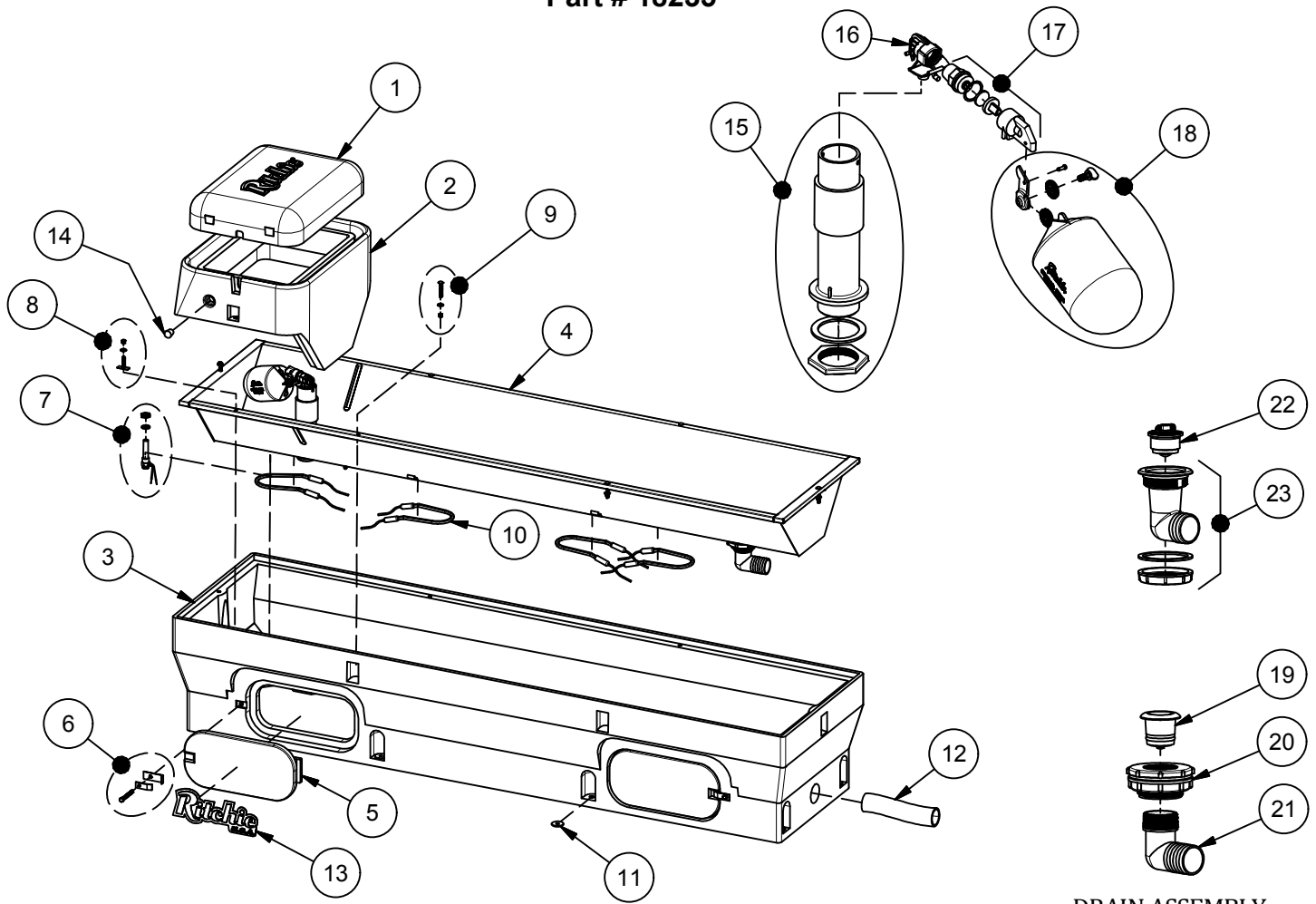

DRAIN ASSEMBLY
PRE-2019 UNITS

Item	Part #	Description	Qty	Item	Part #	Description	Qty
1	18428	CM Cover	1	15	18181	CM Standpipe pkg	1 pkg
2	18349	CM Frame pkg	1 pkg	16	11514	Valve Bracket 3/4" pkg	1 pkg
	18350	CM Cover & Frame pkg	1 pkg	17	15377	Green Male Valve 3/4" pkg	1 pkg
3	18240	CM 840 Casing	1	18	18314	Float with Hardware pkg	1 pkg
4	16786	CM 840 Trough pkg	1 pkg		18313	Hardware for Float pkg	1 pkg
5	16621	Access Panel 6"x14"	2	19	18338	CM Drain Plug pkg	1 pkg
6	18147	Access Panel Hardware pkg	2 pkgs	20	17679	CM Bulkhead fitting 2"	1
7	16534	Fenwal Thermostat SS pkg	1 pkg	21	17678	Drain Elbow Fitting	1
	18320	O-Ring Fenwal (6/pkg)	1 pkg	22	18849	Ritchie 2" Plug pkg	1 pkg
	18074	Nut Brass Fenwal (6/pkg)	1 pkg	23	18852	CM Drain Assembly pkg	1 pkg
8	18266	Frame Bolt & Wshr SS(3/pkg)	1 pkg	NS	12583	Valve Supply Line pkg	1 pkg
9	18265	Trough Bolt & Nut SS (5/pkg)	1 pkg	NS	13830	Cable Htr 120V 48W (1/pkg)	1 pkg
10	11419	Heater 120V 250W (1/pkg)	4 pkgs	NS	18331	CM 840 Accessory pkg	1 pkg
11	18318	Bolt Down Washer (4/pkg)	2 pkgs	NS	14866	Seal Foam 1/2"x3/4"x10' Roll	2
12	17677	Drain Tube 10"	1		18243	CM 840 240V	
13	18653	Ritchie Decal 12" (1/pkg)	1 pkg	NS	11403	Heater 240V 300W (1/pkg)	3 pkgs
14	18633	Plug #3 - Water Channel (2/pkg)	1 pkg	NS	16424	Cable Htr 240V 48W (1/pkg)	1 pkg

CattleMaster 480

Part # 18248

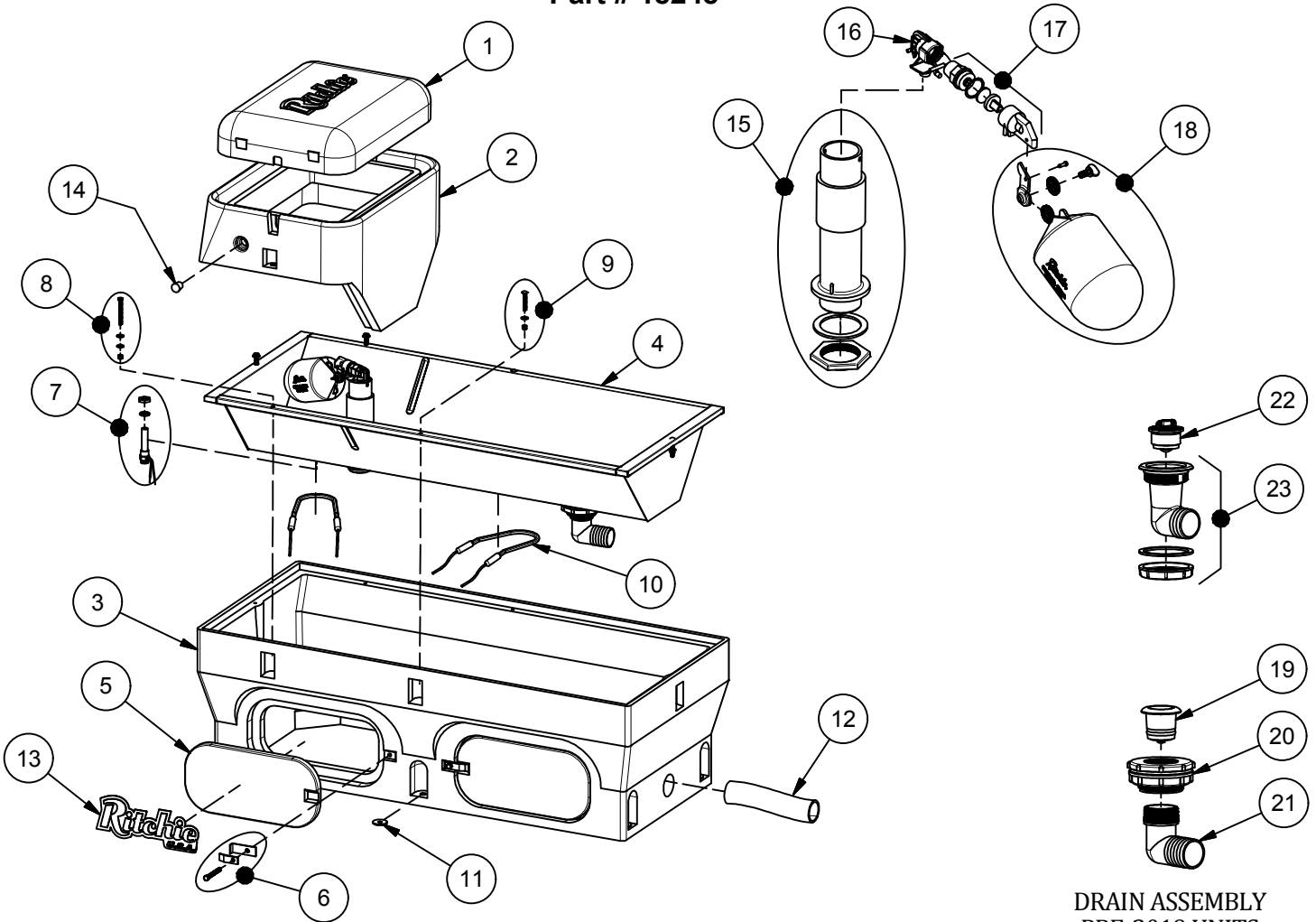

DRAIN ASSEMBLY
PRE-2019 UNITS

Item	Part #	Description	Qty	Item	Part #	Description	Qty
1	18428	CM Cover	1	15	18181	CM Standpipe pkg	1 pkg
2	18349	CM Frame pkg	1 pkg	16	11514	Valve Bracket 3/4" pkg	1 pkg
	18350	CM Cover & Frame pkg	1 pkg	17	15377	Green Male Valve 3/4" pkg	1 pkg
3	18250	CM 480 Casing	1	18	18314	Float with Hardware pkg	1 pkg
4	16780	CM 480 Trough pkg	1 pkg		18313	Hardware for Float pkg	1 pkg
5	16621	Access Panel 6"x14"	2	19	18338	CM Drain Plug pkg	1 pkg
6	18147	Access Panel Hardware pkg	2 pkgs	20	17679	CM Bulkhead fitting 2"	1
7	16534	Fenwal Thermostat SS pkg	1 pkg	21	17678	Drain Elbow Fitting	1
	18320	O-Ring Fenwal (6/pkg)	1 pkg	22	18849	Ritchie 2" Plug pkg	1 pkg
	18074	Nut Brass Fenwal (6/pkg)	1 pkg	23	18852	CM Drain Assembly pkg	1 pkg
8	18266	Frame Bolt & Wshr SS(3/pkg)	1 pkg	NS	12583	Valve Supply Line pkg	1 pkg
9	18265	Trough Bolt & Nut SS (5/pkg)	1 pkg	NS	13830	Cable Htr 120V 48W (1/pkg)	1 pkg
10	11419	Heater 120V 250W (1/pkg)	2 pkgs	NS	18329	CM 480 Accessory pkg	1 pkg
11	18318	Bolt Down Washer (4/pkg)	2 pkgs	NS	14866	Seal Foam 1/2"x3/4"x10' Roll	2
12	17677	Drain Tube 10"	1		18251	CM 480 240V	
13	18653	Ritchie Decal 12" (1/pkg)	1 pkg	NS	11403	Heater 240V 300W (1/pkg)	2 pkgs
14	18633	Plug #3 - Water Channel (2/pkg)	1 pkg	NS	16424	Cable Htr 240V 48W (1/pkg)	1 pkg

Ritchie Limited Warranty

Effective June 2021

Ritchie Industries, Inc. warrants its products to be free of defective materials and workmanship. Defective part(s) will be repaired or replaced at the option of Ritchie Industries. **This warranty specifically excludes all labor and shipping charges.**

This warranty does not apply to any appearance items, to any product whose exterior has been damaged or defaced, to any product that has been improperly installed, to any product subjected to misuse, abnormal service or handling, and to any products altered or repaired with other than original equipment or manufacturer's parts.

This warranty gives you specific legal rights, and you may also have other rights which vary from state to state.

All warranty claims must be processed through an Authorized Ritchie Dealer/ Distributor. **Proof of purchase is required. This warranty is transferable.** The period of warranty begins at original date of purchase as follows:

Poly Units

Base, top and ball closures

10 years limited against manufacturing defect. 100% first five years, then declining 20% per year for the remaining five years.

Stainless Steel Units

Stainless trough and stainless valve chamber frame:

Ten years against manufacturing defect or corrosion. 100% all ten years.

Casing and cover:

10 years limited against manufacturing defect. 100% first year, then declining 10% per year for the remaining nine years.

Component Parts

All component parts, such as floats, valves, heating elements:

One year from the date of purchase against manufacturing defect, 100%.